

ZAMA®

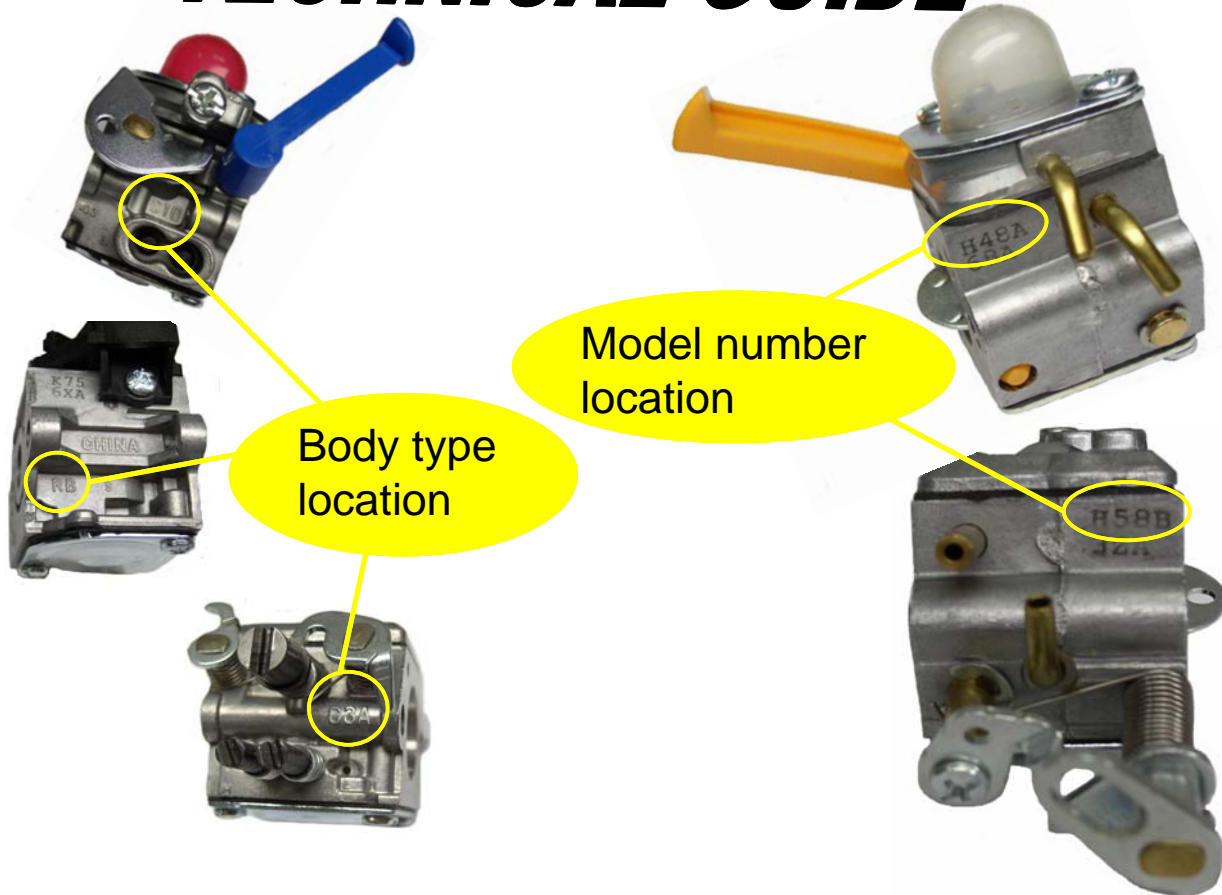

TECHNICAL GUIDE



SYSTEMS AND OPERATION

/// FUEL PUMP SYSTEM

- 1 The fuel pump on a diaphragm carburetor uses the vacuum and pressure pulse from the engines crankcase to move a diaphragm up and down. The pulse travels from the crankcase through a drilled passage or a hose to the carburetor.
- 2 As the diaphragm moves up it expands the area in the pump chamber. This creates a vacuum, which draws fuel through a one-way inlet check valve into the chamber.
- 3 As the diaphragm moves down and compresses the area in the pump chamber the fuel is forced through the one-way outlet check valve to the inlet needle.

It is important to make sure the passage from the engine crankcase to the pump diaphragm is clear and not restricted in any way in order for the pump to operate properly.

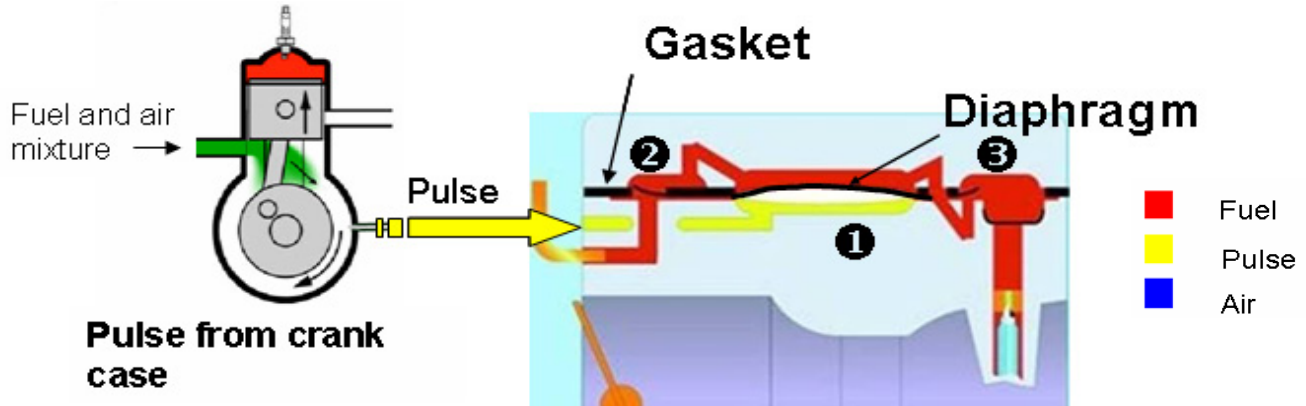

/// FUEL METERING SYSTEM

The purpose of the metering system is to control fuel flow. Its operation is much like a float and inlet needle on a conventional float bowl carburetor. The main advantage of this system is that it is not affected by the orientation of the engine. The components of the fuel metering system consist of an inlet needle, metering lever, metering spring and metering diaphragm.

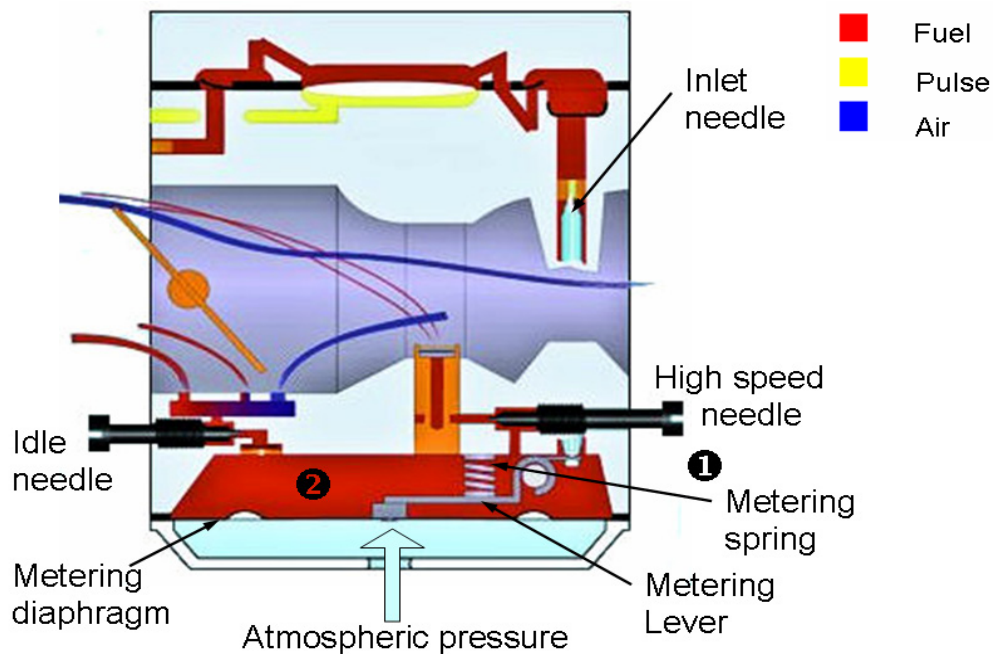

- 1 The pressure of the metering spring against the metering lever holds the inlet needle against its seat and prevents fuel from entering the metering chamber.
- 2 The metering diaphragm is made of a flexible convoluted material to allow for greater movement. As the engine runs, fuel is being drawn from the metering chamber in the carburetor. This causes the metering diaphragm to move up and contact the metering lever. The pressure of the metering diaphragm against the lever over rides the spring pressure on the inlet needle. The fuel pressure from the pump is then great enough to overcome the spring pressure on the inlet needle and fuel flows into the metering chamber.

VENTURI PRINCIPLE OF OPERATION

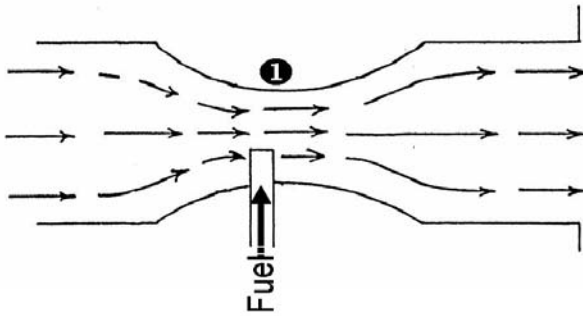

- 1 A venturi is a constriction of the inside diameter of a tube. The “venturi affect” occurs when airflows through a constriction, the airflow speeds up (velocity increases) and the pressure decreases (vacuum increases) at the point of the smallest diameter.

The Venturi is used to produce low pressure inside the bore of the carburetor. The low pressure pulls fuel into the bore from the metering chamber where it mixes with the air and is drawn into the combustion chamber.

PRIMER OPERATION

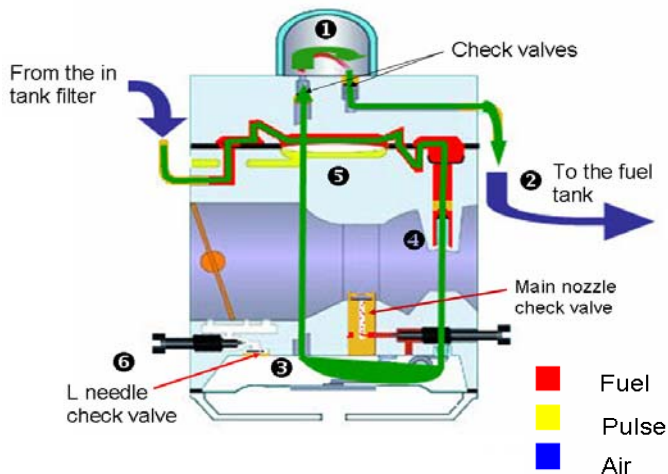

- 5 The open inlet needle causes the vacuum created by the primer to draw fuel from the tank, through the pump, into the metering chamber and up to the primer bulb.
- 6 To prevent air from entering the metering chamber during primer operation there is a one-way check valve in the idle circuit and main nozzle. Every time the primer bulb is depressed this process is repeated causing any old fuel or air that was in the carburetor to be displaced by fresh fuel from the tank. The fresh fuel in the carburetor makes the engine easier to start.

Note that once the metering chamber has been filled with fresh fuel continuing to push on the primer bulb will not help improve the starting of the engine.

STARTING (CHOKE) OPERATION

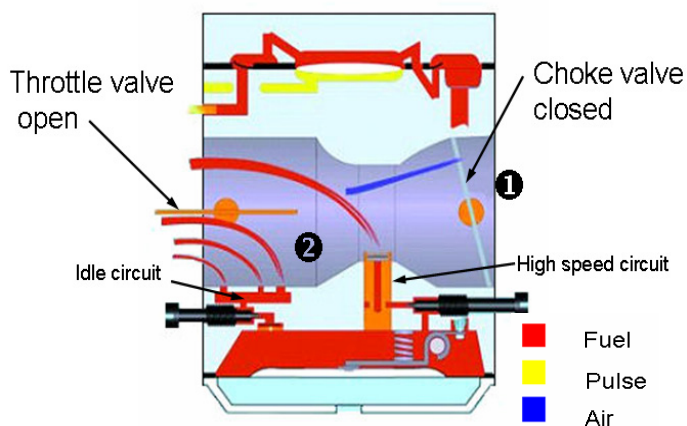

- 1 To start a cold engine the fuel and air mixture entering the engine must be rich. Closing or choking the air inlet of the carburetor using a choke valve accomplishes this. The choke valve allows very little air to enter, causing the engine vacuum to be concentrated inside the venturi of the carburetor.
- 2 The high vacuum draws fuel from the high and low speed fuel circuits creating the very rich fuel and air mixture that is needed to start a cold engine.

The full-choke operation is used to get the engine to fire and start. In most cases the fuel air mixture is too rich to allow the engine to run for a long time before it dies. After the engine starts or “pops” and dies in the full choke position the choke valve is then moved to the half-choke position. The engine is re-started and will continue to run in a rich condition.

After the engine has sufficiently warmed up in the half choke-position the choke valve can be moved to the full open position.

/// IDLE OPERATION

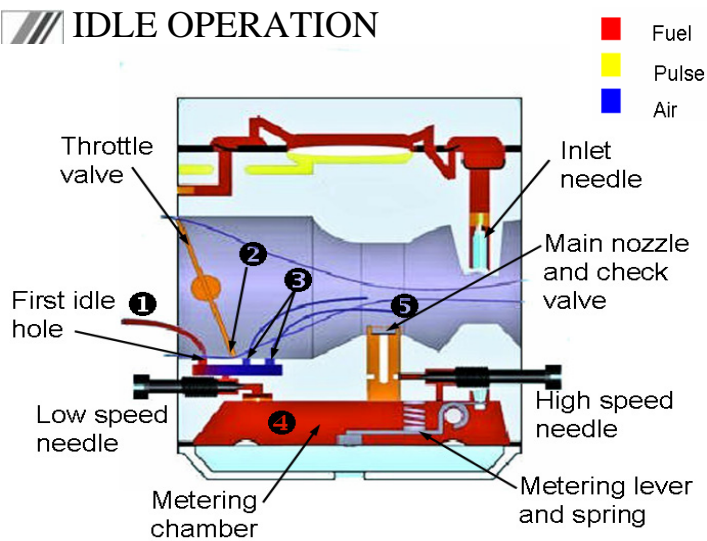

- 1 At idle, fuel is delivered to the engine through the idle or low speed circuit. This circuit usually consist of two or three holes located along the throttle bore of the carburetor.
- 2 The throttle valve is slightly open allowing a small amount of air to pass through to the engine. This creates a low pressure (vacuum) on the engine side of the throttle valve and atmospheric pressure on the inlet other side of the valve.
- 3 Air enters the secondary holes on the atmospheric side of the throttle valve and mixes with the fuel in the idle pocket creating an emulsified air fuel mixture. The low pressure draws the fuel and air mixture through the first idle hole into the engine.

- 4 As the fuel and air mixture is drawn out of idle pocket it creates low pressure in the metering chamber. Atmospheric pressure pushes the metering diaphragm against the metering lever. This releases the spring pressure applied to the inlet needle and allows fuel to flow into the metering chamber.
- 5 The main nozzle check valve is another important component of the idle circuit. This one way check valve located in the main nozzle is under atmospheric pressure at idle. Without it air would flow from the main nozzle into the metering chamber. This will cause an air leak in the metering chamber and there would be no drop in pressure. The diaphragm will not move and the engine will die lean when idling. This check valve also serves the same function during the priming operation.

/// PART THROTTLE OPERATION

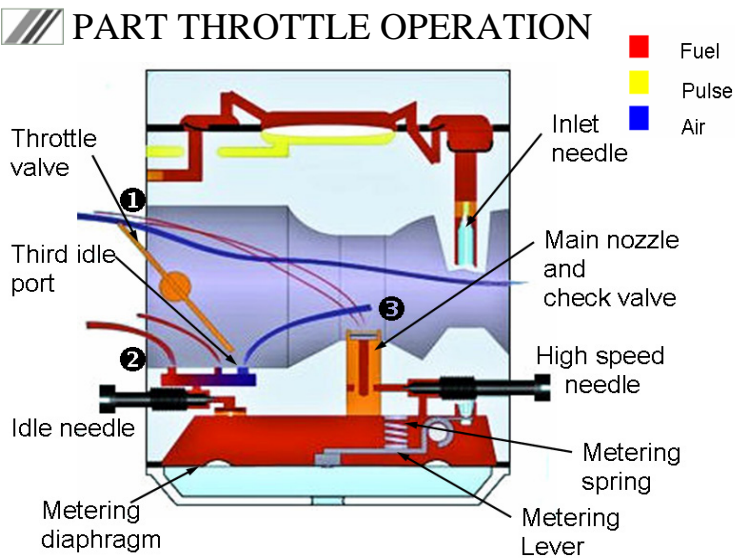

- 1 During part throttle operation or acceleration the throttle valve is opened to allow more air to the engine.
- 2 As airflow increases so must fuel flow to maintain a proper air/fuel mixture. The secondary idle holes are now on the vacuum side of the throttle valve and fuel is drawn through all the idle circuit holes.
- 3 The increased airflow causes vacuum to be applied to the main nozzle. This allows fuel pressure from the metering chamber to overcome atmospheric pressure on the check valve and it begins to flow fuel to the engine.

/// WIDE-OPEN THROTTLE OPERATION

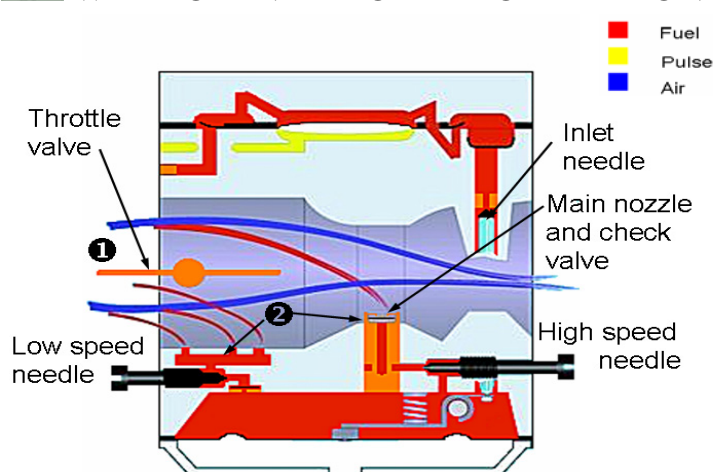

- 1 The throttle valve is opened completely allowing maximum airflow through the venturi.
- 2 The pressure drop from the venturi increases fuel flow from the main nozzle. Fuel from the main nozzle and idle circuit mixes with the air, entering the combustion chamber and satisfying the requirements of the engine.

TROUBLE SHOOTING DIAPHRAGM CARBURETOR PROBLEMS

Engine problems that can be mistaken for carburetor problems

Performance problem		Hard starting / no start	Will not idle / no start	Erratic idle / unstable	Lean engine / stalls at W.O.T.	Poor acceleration / stalls at idle	low power at W.O.T.	Rich engine / flooding
Inspect possible fault	Engine Air leaks / bolts loose / gaskets damaged	●	●	●	●	●		
	Plugged / restricted fuel pump pulse passage	●	●	●	●	●	●	
	Air filter restricted (dirt / fuel)		●	●			●	●
	Fuel line leakage	●	●	●	●	●	●	
	Piston/cylinder damaged or scuffed	●	●	●		●	●	
	Restricted muffler	●	●	●		●	●	
	Dirt in fuel system / old fuel	●	●	●	●	●	●	
	Dirty / fouled spark plug	●	●	●		●	●	
	Fuel tank vent open or restricted	●		●	●	●	●	●
	Faulty ignition switch / module	●	●	●		●	●	
	Throttle linkage binding		●	●		●	●	
	High engine friction or load	●	●	●		●	●	

Chart 1

This section describes the procedure recommended to properly diagnose a Zama diaphragm carburetor problem on a two-cycle engine.

If you have an engine performance problem and suspect the carburetor the first thing that must be done is to confirm that you actually have a carburetor problem. Above is a trouble-shooting guide that can help you diagnose engine problems that can often be mistaken for the carburetor. We will assume you have confirmed the following items and inspected all the possible faults as specified in chart 1.

Common things to check that can effect carburetor performance.

- Engine compression and crankcase vacuum are to manufacturers specs.
- Good ignition system and spark plug.
- Crankcase pulse passage is clear.
- Carburetor and manifold bolts are tight.
- Low speed and high-speed enrichment needles are adjusted to manufacturers recommendations.
- Idle speed screw is adjusted to manufacturers recommended idle speed.

Carburetor related problems trouble shooting guide

Performance problem		Hard starting / no start	Will not idle	Rich idle / no start	Erratic idle / loads up	Idles with low speed needle closed	Engine with low speed needle closed	Poor acceleration / dies	low power at deceleration	Rich engine / flooding	Rich engine / W.O.T. / dies
Possible fault	Idle mixture screw not properly adjusted	●	●	●	●			●	●	●	
	High speed mixture screw not properly adjusted	●						●	●	●	
	Throttle adjust screw adjustment		●						●		
	Throttle shaft, plate (loose/worn)	●				●		●			
	Choke shaft, plate (loose/worn)	●	●								
	Fuel pump diaphragm (leaking/stiff)		●	●	●	●		●	●	●	●
	Strainer (restricted/plugged)	●	●						●	●	
	Inlet needle valve stuck	●	●								
	Inlet needle leaking (dirt/worn tip/worn seat)	●		●	●						●
	Metering lever, spring (worn/binding)	●	●	●	●				●	●	●
	Metering lever set to high	●		●							●
	Metering lever set to low	●							●	●	
	Atmosphere vent hole, metering cover (restricted)	●	●						●		
	Metering diaphragm gasket (leaking/stiff/cover screws loose)	●		●	●			●	●		
	Welch plug leaking	●		●			●				●
	Low speed fuel passage restricted/dirty	●	●			●			●		
	High speed fuel passage restricted/ dirty	●									
	Idle and main mixture screws seats damaged	●	●	●	●	●					●
	Main nozzle check valve closed/restricted	●								●	
	Main nozzle check valve leaking	●				●		●			
Accelerator plunger stuck (if equipped)								●			

After ruling out any engine related performance problems use chart 2 to help determine the fault for the carburetors malfunction.

If the diagnoses result in action that involves repair of the carburetor then follow the disassembly and service instructions on the subsequent pages.

ZAMA CUBE CARBURETOR DISASSEMBLY AND SERVICE

MIXTURE SCREWS

- Remove idle and main mixture screw.
- Inspect each screw for damage, especially the needle points which should have no deformation of the tapered surfaces.
- A damaged needle or seat will result in a very sensitive needle. The needles will be difficult to adjust and the carburetor will always run too rich or too lean.

Note: On dual needle carburetors the L and H needle are not interchangeable. Remember that the L needle is always longer.



FUEL PUMP

FOR LA/LB TYPE:

- Remove fuel strainer cover and strainer.
- Remove pump diaphragm and pump gasket.
- Inspect pump diaphragm, replace if diaphragm shows any signs of wear or curling.
- Remove metering chamber cover.
- Remove metering diaphragm and metering chamber gasket.
- Inspect metering diaphragm for dirt and foreign matter. Remove pump cover screws and pump cover.

FOR ALL OTHER TYPES: C1U, C1Q/M, C2, C3, C3A/M

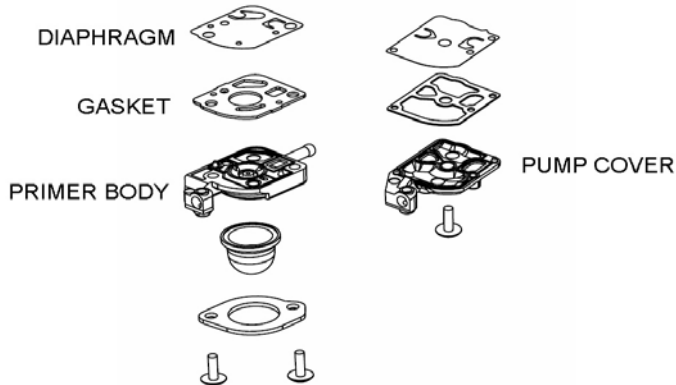

- Remove pump cover screws and pump cover or primer body.
- Remove pump gasket and pump diaphragm.
- Inspect pump diaphragm, replace if diaphragm shows any signs of wear, wrinkles or tears.
- Remove strainer.

METERING DIAPHRAGM

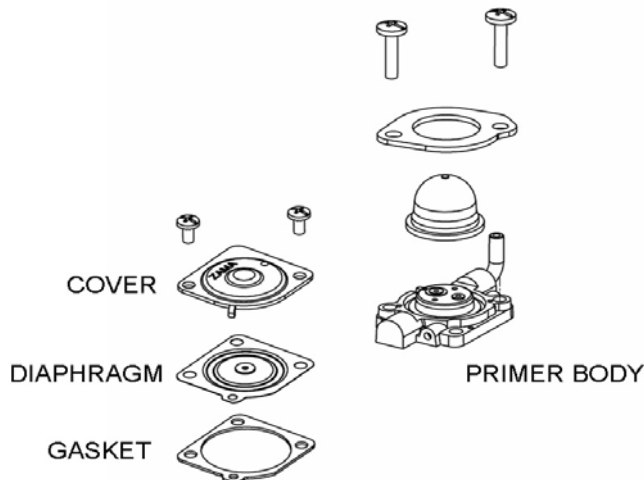

- Remove screws and metering chamber cover or primer body.
- If metering diaphragm is hooked type, remove it, being careful to un-hook it from metering lever.
- Remove metering chamber gasket.
- Inspect metering diaphragm for dirt and foreign matter.

INLET NEEDLE VALVE

- If the carburetor is equipped with a plastic metering disk, remove it carefully. The disk must be smooth and free from cracks or chipped edges. The center tip that fits into the metering lever hole must be secure and not broken or worn.
- The following instructions apply to all models.
- Remove metering lever screw.
- Remove metering lever, pin, metering lever spring and inlet needle valve.
- Inspect the metering lever. It should not be worn where it contacts the inlet needle valve and metering disk.
- Inspect inlet needle valve. The tip should not be deformed where it contacts the seat.

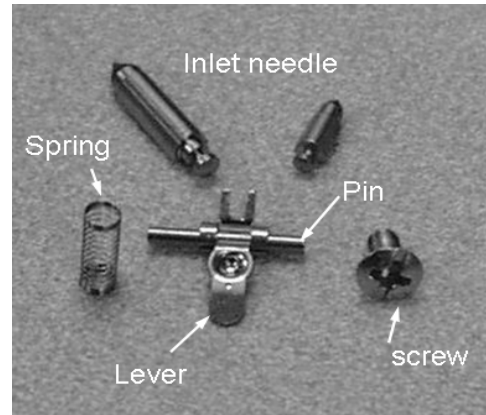
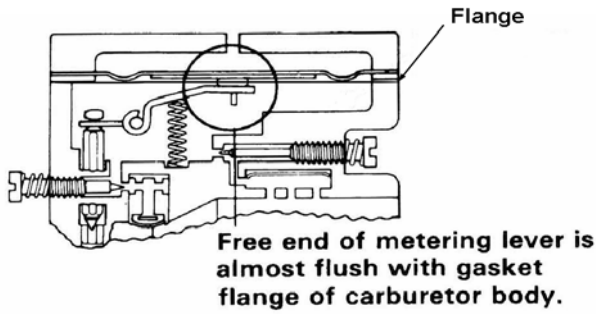

WELCH PLUG

- Under the extreme conditions of a clogged idle port and channel, it may be necessary to remove the welch plug. Do this operation very carefully. If the carburetor is equipped with the priming pump, do not attempt to remove the welch plug unless you are certain the check valve in the idle chamber is malfunctioning.
 - Use a small 2/32 to 3/32 inch diameter sharp pointed punch to pierce the welch plug.
 - Just below the welch plug there is a thin casting wall where the idle and secondary holes are located. Punching through this area will ruin the carburetor body casting. Let the punch just pierce the welch plug, then carefully pry the welch plug out of the body casting.
 - If the carburetor is equipped with the plastic filling in the idle chamber, it will be unusable when the welch plug is removed. So, replace the plastic filling.
- Note: It is often un-necessary to remove the welch plug. Test for plugged progression holes by spraying carb cleaner into the L needle hole. If cleaner sprays out the progression holes there is no need to remove the welch plug.

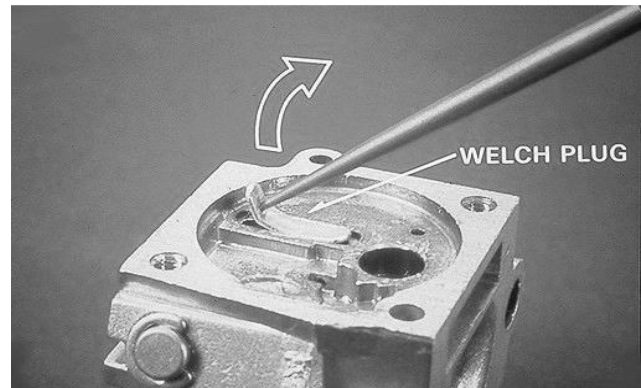

LOCATION CHART FOR PIERCING WELCH PLUGS

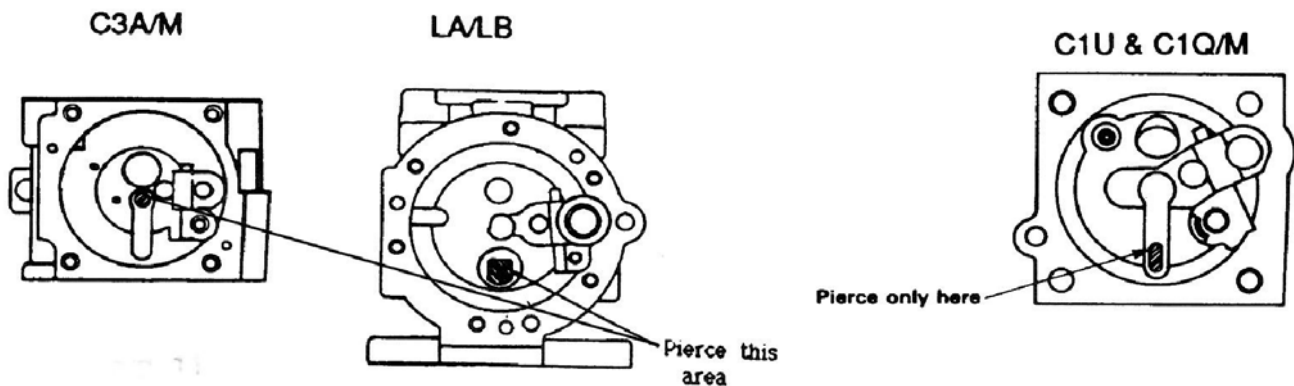

NOZZLE

- Test the main nozzle by blowing air by mouth through the H needle feed hole with a small hose. With the needle open 2 turns open air should flow through, but you should not be able to suck air back.
- Before removing nozzle assembly, make sure the main mixture screw was already removed.
- If the carburetor is equipped with a pressed in nozzle assembly, do not attempt to remove it unless you are certain it is malfunctioning. If it is necessary to remove, carefully press it out with steel rod or punch slightly smaller in diameter than the nozzle.
- If the carburetor is equipped with a screw in nozzle assembly, remove it in the same manner as a normal screw.
- If the carburetor is equipped with strainer and C-ring type, remove main welch plug, then remove C-ring and retainer. It is not necessary to remove nozzle.
- The strainer and retainer type is not repairable. Clean them using gasoline and compressed air.

CARBURETOR BODY

- Clean the carburetor body. Channels can be cleaned by blowing through the idle and main adjusting orifices with spray carburetor cleaner. Do not soak in dip tank type cleaner. Do not use wires or drills to clean orifices. Inspect the operation of the throttle valve and lever.

REASSEMBLY

- * Replace all worn parts and make sure that all parts are clean before they are reassembled into carburetor body.

NOZZLE

- Make sure the main mixture screw was removed, before reassembling the nozzle assembly.
- If nozzle assembly is a pressed in type, put a light oil film on the outside of the nozzle check valve cage.
- Carefully press the nozzle into the carburetor body until it is just flush with the metering chamber.
- If the carburetor is a strainer and C-ring type, install the strainer and C-ring. Lay the main welch plug into the cavity and press it firmly with a flat end punch to expand it tightly against the sides of the cavity.
- If nozzle assembly is a screw in type, reassemble in the same manner as a normal screw.

WELCH PLUG

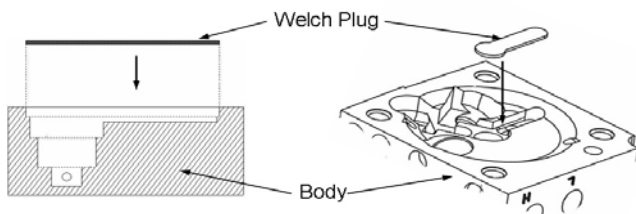

- Lay the welch plug into the cavity. If the welch plug is circle shape, press it firmly with a flat end punch to expand it tightly against the sides of the cavity. If the welch plug is oblong shape, press it firmly with oblong punch.
- Lay the welch plug into the cavity. Press it firmly with oblong punch. It is best to use sealer for sealing around the welch plug.

INLET NEEDLE VALVE



- Inspect the metering lever and the pin.
- Assemble the lever onto the pin and rotate the pin. The lever should fit easily on the pin and not stick.
- Install the inlet needle valve, metering spring, metering lever, pin and retaining screw.
- Adjusting the metering lever. The Zama "Z" gauge is designed to adjust all models. Hold the gauge against the body as shown using the proper side designated for the model you are adjusting. The end of the metering lever should touch the gauge. A straight edge can also be used as described on the next page.

(A) If the metering lever is the same as Figure a in the following schematic, place a straight edge or Zama Z gauge across the carburetor body. The free end of the metering lever should be 0 to 0.3 mm - 0 to 0.012" below the straight edge.

(B) If the metering lever is the same as Figure b in the following schematic, the free end of the metering lever should be flush with the cavity floor. (1.7mm to 2.0 mm - 0.067" to 0.078" below the metering gasket flange of carburetor body).



ADJUSTING THE METERING LEVER HEIGHT



Zama Z-gauge

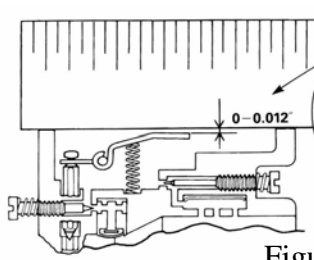

Figure a

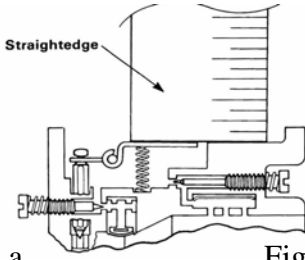
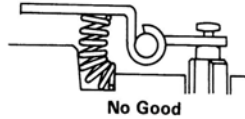
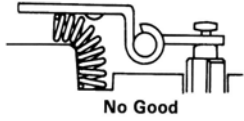
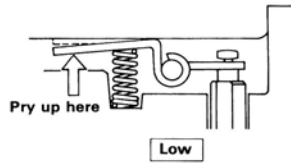
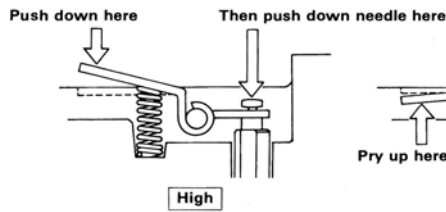

Figure b

If the metering lever is too high, push down on the free end of the lever, then carefully push down on the inlet needle, if the metering lever is too low, pry up carefully on the free end of the lever.



- Make sure the metering lever spring is seated at the bottom of the casting pocket and under the dimple in the metering lever.



- If the metering lever is too high, push down on the free end of the lever, then carefully push down on the inlet needle, if the metering lever is too low, pry up carefully on the free end of the lever.



METERING DIAPHRAGM AND FUEL PUMP

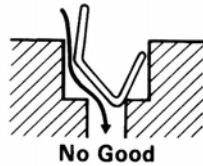
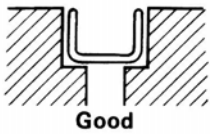

- Install the fuel strainer to the pump cover using a flat end punch of a diameter nearly equal to the inside of the strainer.



METERING CHAMBER FOR ALL CUBE TYPES: C1U, C1Q/M, C2, C3, C3A/M

METERING CHAMBER COVER



METERING DIAPHRAGM



METERING CHAMBER GASKET

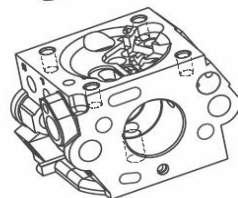

- If the carburetor is equipped with a plastic disk, install it onto the metering lever by placing the molded tip into the hole in the free end of the metering lever.
- Install the metering chamber gasket, metering diaphragm, metering chamber cover and screws. Metering chamber gasket and metering diaphragm should be assembled in the proper order.
- Install the fuel strainer using a flat end punch of a diameter nearly equal to the inside of the strainer. Push the screen straight into the casting to the bottom of the bore.

FUEL PUMP FOR ALL CUBE TYPES: C1U, C1Q/M, C2, C3, C3A/M

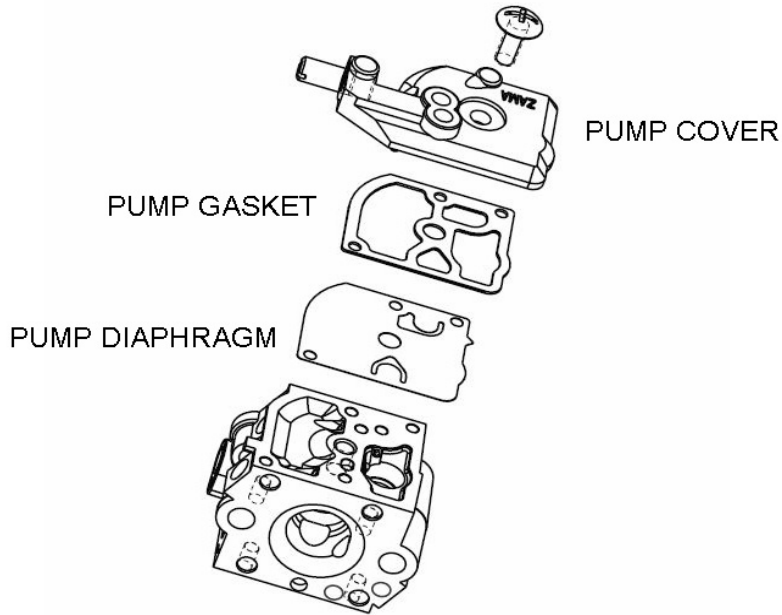

- Install the pump diaphragm, pump gasket, pump cover and screw. Pump diaphragm and pump gasket should be assembled in the proper order.

METERING DIAPHRAGM AND PUMP FOR LA/LB TYPE:

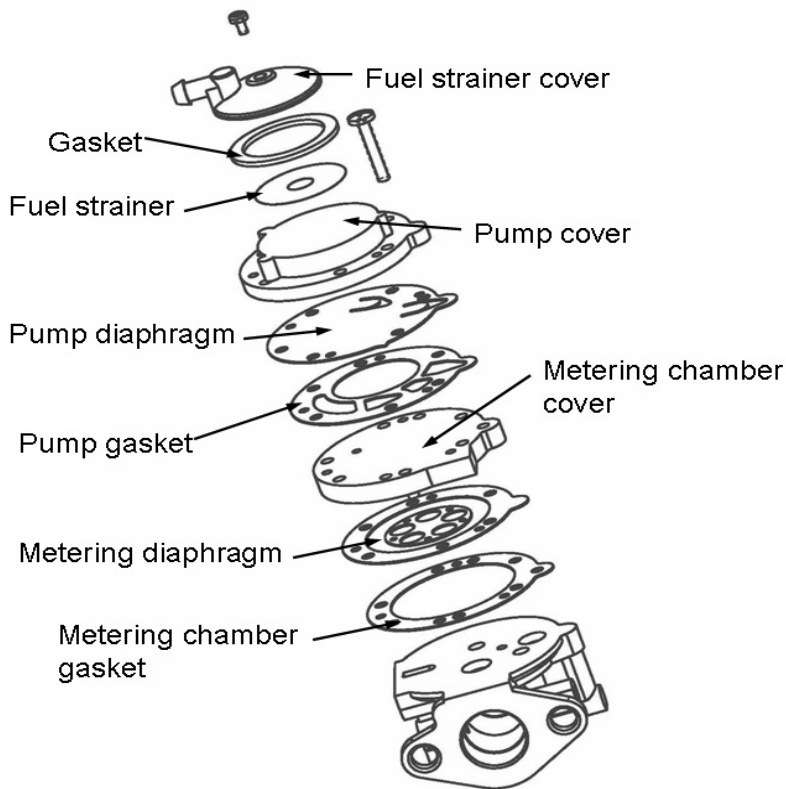

- Install the metering chamber gasket, metering diaphragm, and metering chamber cover. Metering chamber gasket, and metering diaphragm should be assembled in proper order.
- Install the pump gasket, pump diaphragm and pump cover. Pump gasket and pump diaphragm should be assembled in proper order.
- Carefully install the fuel strainer. Push the screen straight into the casting to the bottom of the counter bore. Install the gasket, fuel strainer cover and screw.

ZAMA RB ROTARY CARBURETOR

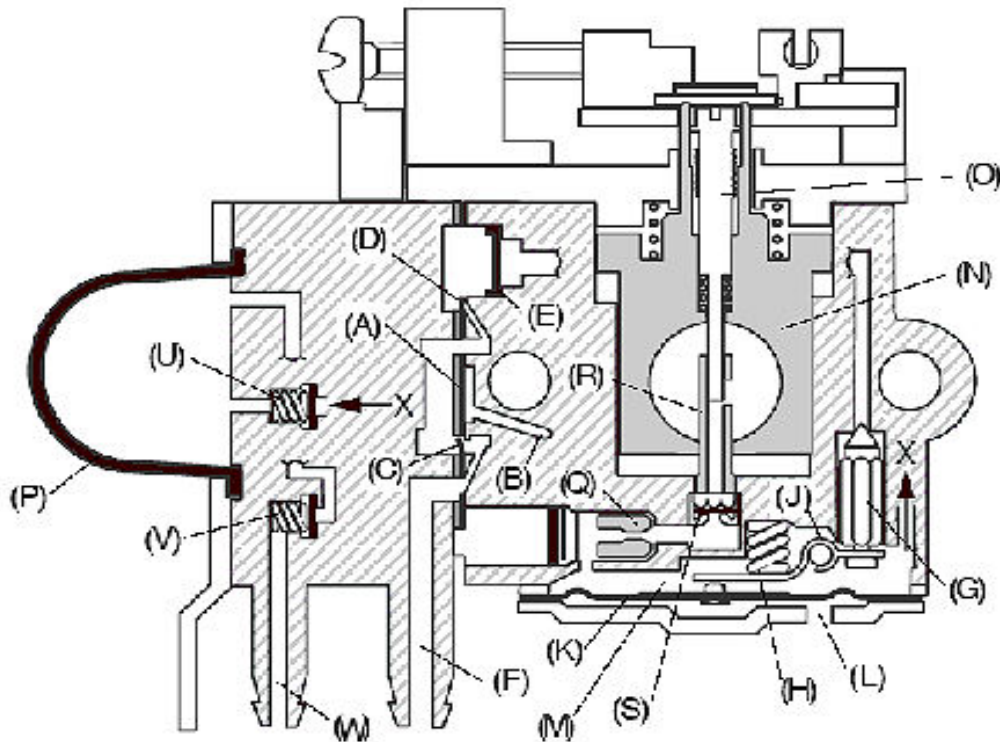

- (A) **Pump diaphragm** : Fluctuates in response to crankcase pulses. Transfers fuel from the tank to the inlet needle valve.
- (B) **Crankcase pulse** : Actuates fuel pump diaphragm with alternating positive and negative pressure pulses.
- (C) **Fuel pump inlet check valve** : Opens during negative pressure pulse. Closes during positive pressure pulses.
- (D) **Fuel pump outlet check valve** : Closes during negative pressure pulse. Opens during positive pressure pulse.
- (E) **Inlet screen** : Filters fuel in route to metering chamber.
- (F) **Fuel inlet** : Draws fuel from tank.
- (G) **Inlet needle valve** : Lifts off seat to allow fuel entering metering chamber.
- (H) **Metering lever spring** : Transmits force to metering lever. Closes inlet needle valve as metering chamber is filled.
- (J) **Metering lever** : Lifts inlet needle valve out of seat.
- (K) **Metering diaphragm** : Depressed by atmospheric pressure to activate metering lever.
- (L) **Atmospheric vent** : Allows atmospheric pressure onto dry side of metering diaphragm.
- (M) **Metering chamber** : Fuel reservoir, feeds fuel to main nozzle.
- (N) **Throttle valve** : Regulates engine speed, as controlling the air volume mixed with discharged fuel from main nozzle.
- (O) **Throttle valve needle** : Controls fuel at main nozzle.
- (P) **Purge bulb** : Pumps fuel from the fuel tank through the carburetor fuel pumps and metering chamber back to the fuel tank, purging air from the carburetor.
- (Q) **Main jet** : Meters correct amount of fuel to be delivered to main nozzle.
- (R) **Main nozzle** : Discharges fuel metered by main nozzle to mix with air at throttle valve.
- (S) **Main jet check valve** : Closes to prevent air from entering metering chamber when purge pump is operating.
- (U) **Inlet check valve** : Allows fuel to be sucked up to purge bulb.
- (V) **Outlet check valve** : Allows fuel to be forced to fuel return fitting.
- (W) **Fuel return fitting** : Return fuel to tank through return pipe.

PRINCIPLES OF OPERATION

PRIMER PURGE PUMP

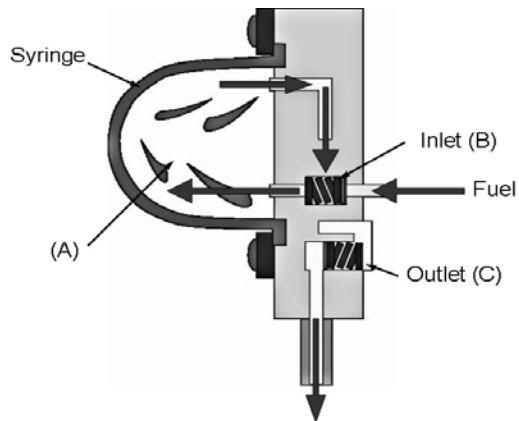

- The purge pump is comprised of purge bulb (A), inlet check valve (B) and outlet check valve (C).
- When the purge bulb (A) is depressed, the outlet check valve (C) opens and air or fuel is forced through the outlet check valve (C) to the fuel return hose fitting.
- When the purge bulb (A) is released, the outlet check valve (C) closes and the inlet check valve (B) opens to draw fuel from the metering chamber.
- Vacuum created by the expanding bulb draws fuel from the fuel tank through the fuel passages of the carburetor into the purge bulb (A).

THROTTLE BODY

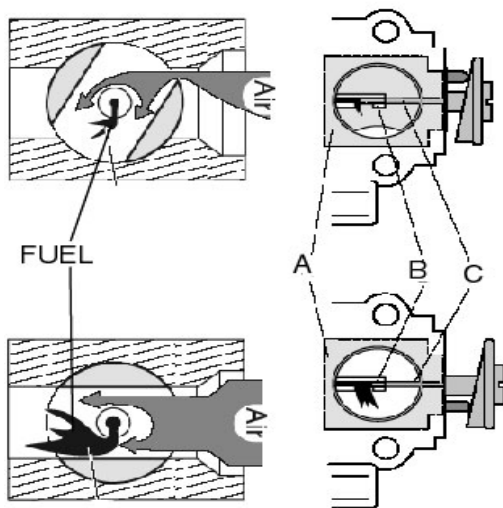

- The throttle valve (A) is a hollow barrel. Rotation of the throttle valve controls the opening of the throttle and also controls the air volume.
- The main nozzle (B) has a slot port to discharge and is located in the center of the throttle valve for maximum air velocity. The throttle valve needle (C) is installed into the main nozzle to control fuel volume. The throttle valve needle moves upward by cam action of the throttle valve, proportionate to the opening the throttle valve.
- At idle the throttle valve is slightly open. The valve needle is at its lowest position, the main nozzle only slightly open.
- As the throttle is opened, the opening of the valve enlarges to allow more airflow into the valve and simultaneously raises the throttle valve to increase fuel flow from the main nozzle.

FUEL PUMP

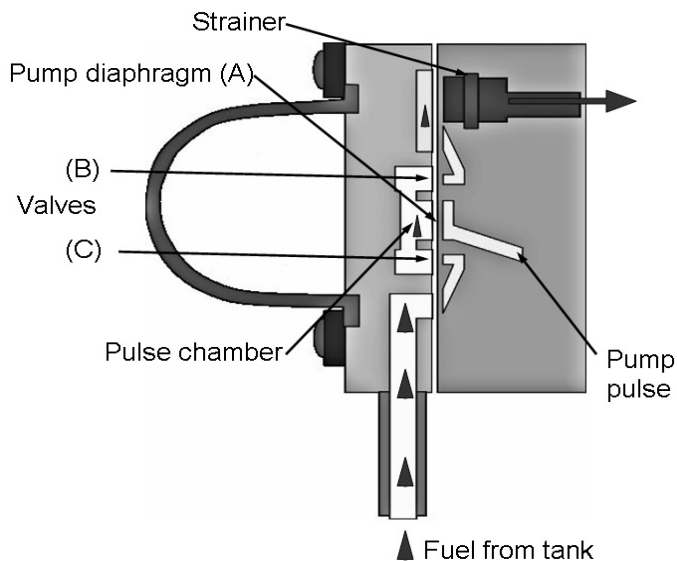

- The diaphragm (A) is operated by alternating positive pressure and negative pressure pulses generated in the crankcase.
- The valve (B) and (C) open and close alternately to direct the fuel flow from the fuel tank to the inlet needle valve. Fuel is filtered by the strainer prior to entering the metering chamber.

METERING CHAMBER AND INLET NEEDLE

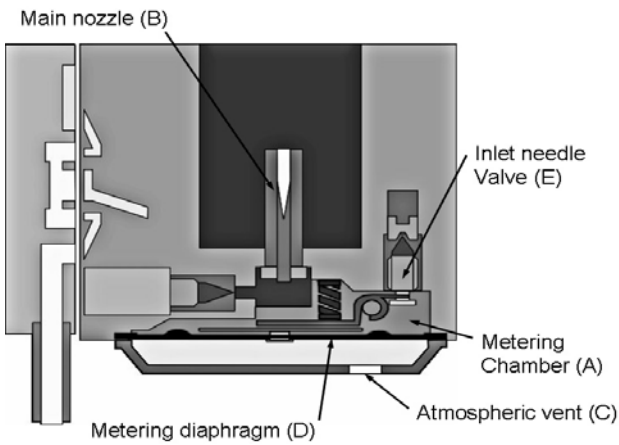

- The metering chamber (A) functions as a reservoir for fuel.
- As the engine rotates, air is drawn into the throttle valve by crankcase vacuum. This creates depression in the area of the main nozzle (B).
- Atmospheric pressure acting through the atmospheric vent (C) depresses the metering diaphragm (D) forcing fuel from the main nozzle (B) and simultaneously opening the inlet needle valve (E) to allow fuel into the metering chamber (A).
- The metering diaphragm controls the amount of fuel in the metering chamber.

RB ROTARY DISASSEMBLY AND SERVICE

FUEL PUMP

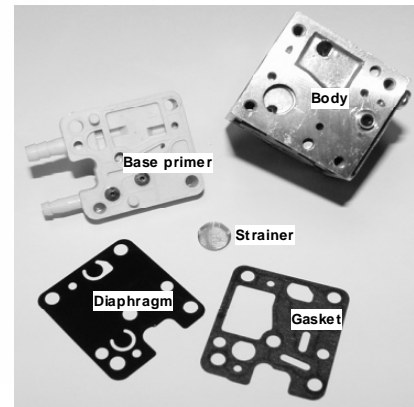
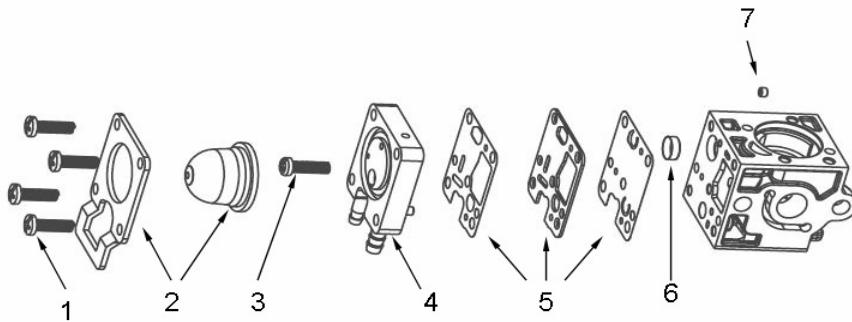

1. Remove four syringe retainer screws.
2. Remove syringe retainer and syringe.
3. Remove base primer screw. Remove base primer. Replace if primer does not function.
4. Remove surge diaphragm, pump gasket, and pump diaphragm.
5. Inspect pump diaphragms and gasket, replace if they show any signs of wear, wrinkles, curling or tears.
6. Remove fuel strainer installed in the carburetor body. Inspect for dirt and foreign matter. Replace if necessary.
7. Inspect and clean roller. Pay attention when disassembling carb to remove the roller and set aside so that it is not misplaced when cleaning the body.

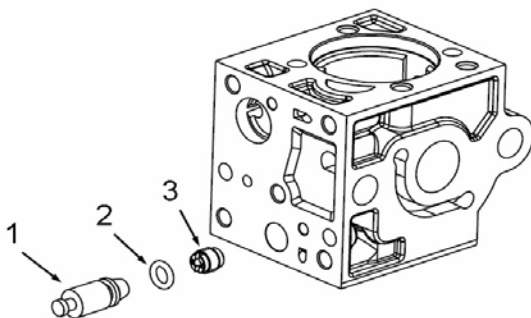

1. Remove plastic nozzle plug.
2. Inspect nozzle plug and o-ring. Replace if they show any signs of wear.
3. Remove jet. Inspect for damage. Do not run drill or wire through jet for cleaning.

METERING DIAPHRAGM AND INLET NEEDLE VALVE

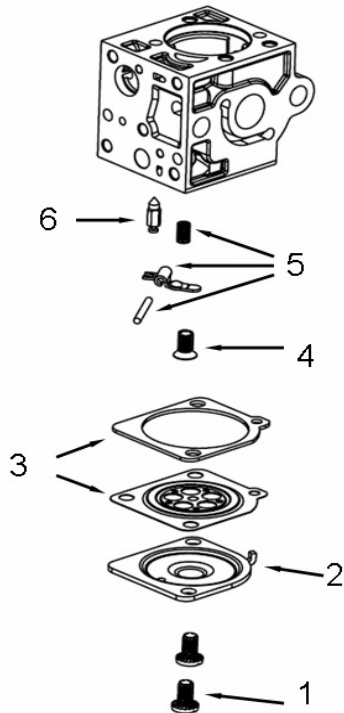

1. Remove two metering cover screws.
2. Remove metering chamber cover.
3. Remove metering diaphragm assembly and metering cover gasket. Inspect metering diaphragm for dirt and foreign matter, replace if they show any signs of wear, wrinkles, curling or tears.
4. Remove metering lever screw.
5. Remove the metering lever, pin and spring. Inspect the metering lever; it should not be worn where it contacts the inlet needle valve or pin. Replace if necessary.
6. Remove and inspect the inlet needle valve. The tip should not be deformed where it contacts the seat. A ring on the needle tip is normal. When you run your thumbnail across the surface of the tip you should not feel groove. Replace it if necessary.

Adjustment of metering lever for RB models

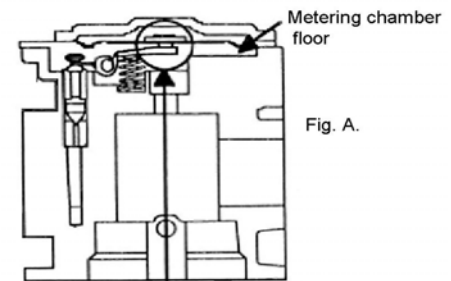

Free end of metering lever is about flush with the gasket flange of the carburetor body.

NOZZLE

- Nozzle Assembly cannot be removed.
- Clean with aerosol cleaner and compressed air.

ROTOR

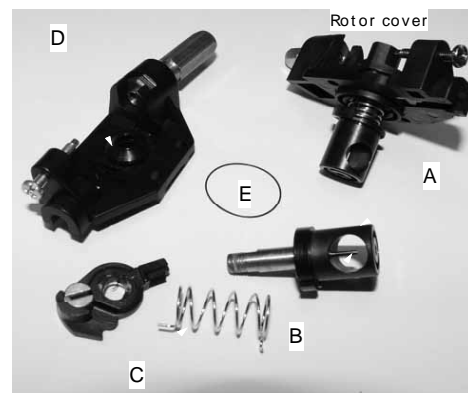
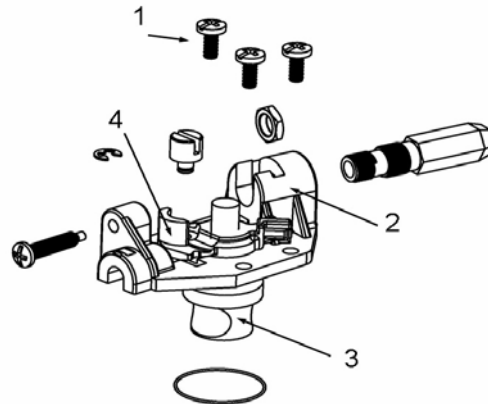

1. Remove two rotor cover screws.
2. Remove rotor cover carefully.
3. Inspect rotor for damage. Rotor assembly should not be broken or worn. Areas to look for wear are A) rotor B) jet needle C) return spring D) boot E) O-ring.
4. Remove Rotor guide carefully. The plastic guide must be smooth and free from cracks or chipped edges.

CARBURETOR BODY

- Clean the carburetor body. Channels can be cleaned with aerosol cleaner and or compressed air. Do not use wires or drills to clean the orifices. Inspect the operation of the throttle valve and lever.

SERVICING THE SIMPLE START® SYSTEM:

Operation:

As the Start Pump receives the crankcase pressure and vacuum pulses, it begins to suck fuel from the metering chamber into the start pump, and spray it out of the injector hole in the throttle bore. As the engine warms up it does not need this extra fuel so it begins running richer and richer and begins to slow down. If Simple Start is left on, the engine will eventually get too rich and die.

Possible Failure Modes:

1) Will Not Start:

First make sure the rest of the carburetor functions properly. Do this by starting the engine either by choking it with your hand or priming it with some fuel through the carburetor throat. The Simple Start system is calibrated to work with the properly adjusted, properly operating carburetor. If the rest of the engine and carburetor operates properly, but the Simple Start pump is not delivering fuel, and easy initial check can be done.

While running the engine engage the start system. If the engine accelerates when the system is engaged and then gradually slows down and dies, the system is working. Occasionally the small passages in the starting circuit become clogged by small drops of oil or trash and running the engine will clear these obstructions. If running the engine does not fix the system then proceed with the diagnosis.

Make sure the crankcase pulse passages are open. Check the carb mount and gaskets to make sure no sealer or a mis-aligned gasket is blocking the pulse hole. Make sure the actuating system is functioning.

Inlet check valve; you should not be able to suck air back through it. The OUTLET check valve can also be tested in this way, however it contains a metering spring so you should not be able to suck or blow air easily through it.

If the check valves are not functioning properly, you can attempt to clean them by directing some spray carburetor cleaner through them. DO NOT BLOW COMPRESSED AIR THROUGH THEM. If the check valves cannot be cleaned, replace the start pump body.

The fuel pump gasket and diaphragm are serviceable parts. The gasket goes on next to the start pump body, with the diaphragm on top of it.

2) Starts but dies

The other possible failure mode is leaking. If the Simple Start pump does not shut off or if the outlet check valve becomes damaged the system will leak fuel and affect the carburetor mixture settings.

1) Is the pulse being shut off? It takes a very small amount of pulse to operate the pump. Make certain the levers controlling the simple start pulse are correctly positioned to completely shut off the pulse in the run mode.

2) Is the outlet check valve working? Again test the outlet check valve with a piece of primer hose. Gently blow through the check valve by mouth or with a carburetor pressure tester. The outlet check valve should offer resistance to airflow.

If the outlet check valve is sticking open, it can be cleaned with a spray carburetor cleaner. If cleaning does not fix it, replace the start pump body.